



LEFROY BROOKS

IBROC HOUSE ESSEX ROAD
HODDESDON HERTS EN11 0QS UK
T: +44 (0)1992 708 316 F: +44 (0)1992 708 317

XO-3015

JO MONO - WALL MOUNTED - SHORT REACH

DIMENSIONAL DATA SHEET

DATE: 18 August 2010

NUMBER: 30 069 3015 C

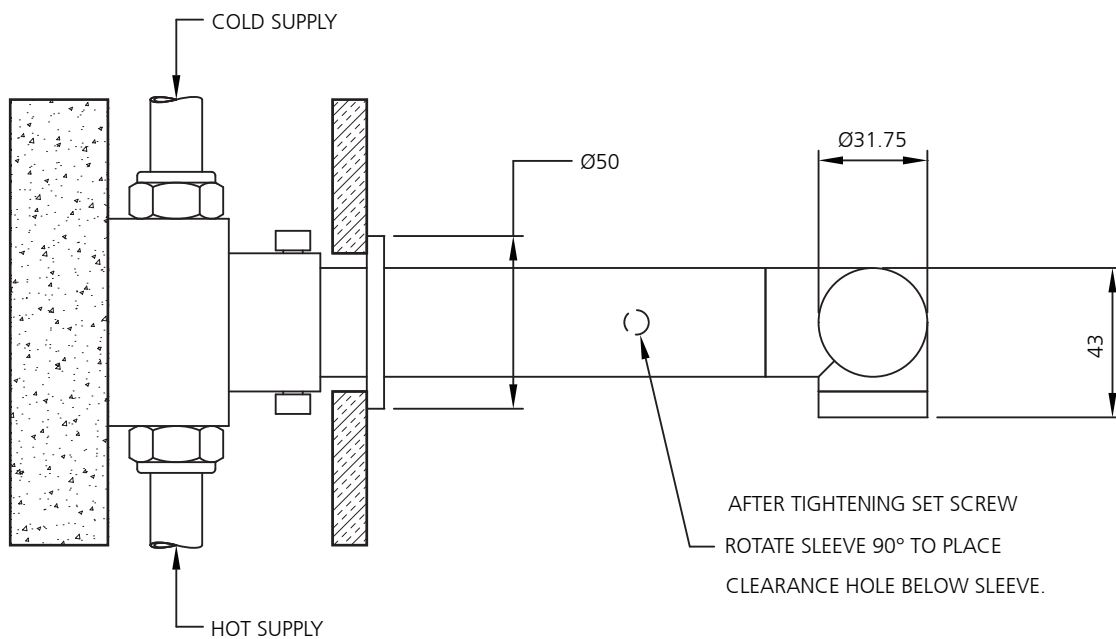
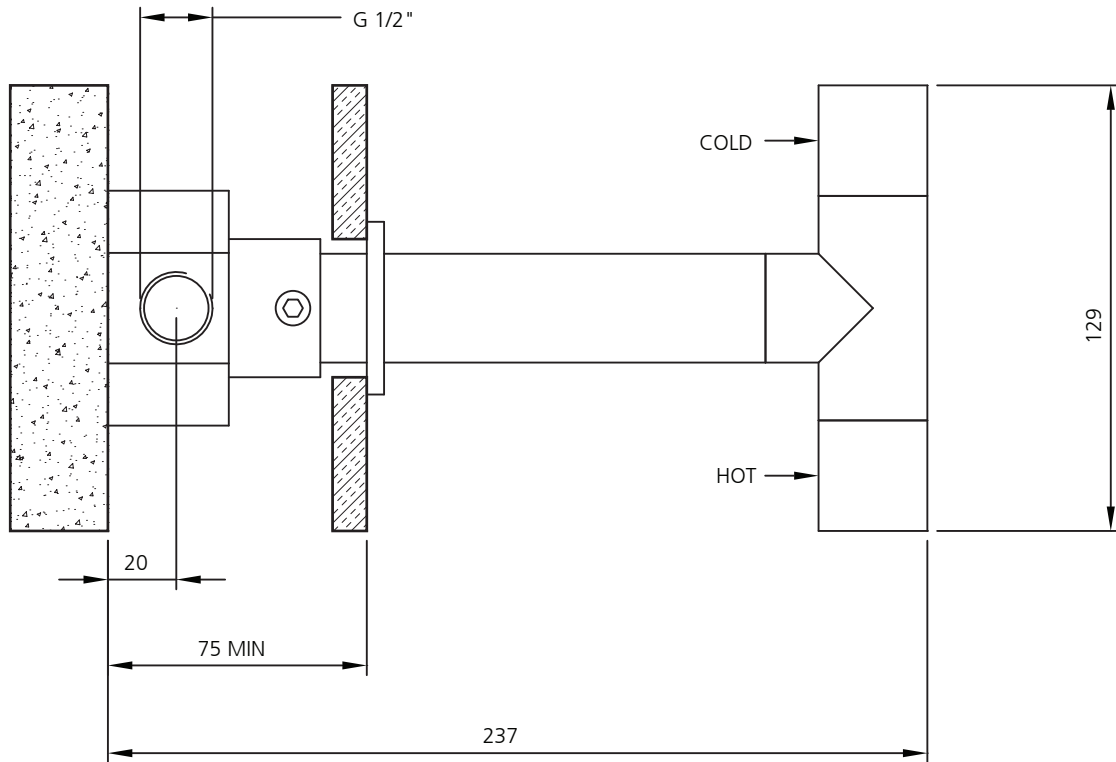

DIMENSIONS IN MILLIMETRES

WHILST EVERY EFFORT IS MADE TO ENSURE THE ACCURACY OF THESE DATA SHEETS THEY ARE SUBJECT TO CHANGE WITHOUT NOTICE AS PART OF THE COMPANY'S PRODUCT DEVELOPMENT PROCESS

XO-3015

JO MONO - WALL MOUNTED - SHORT REACH

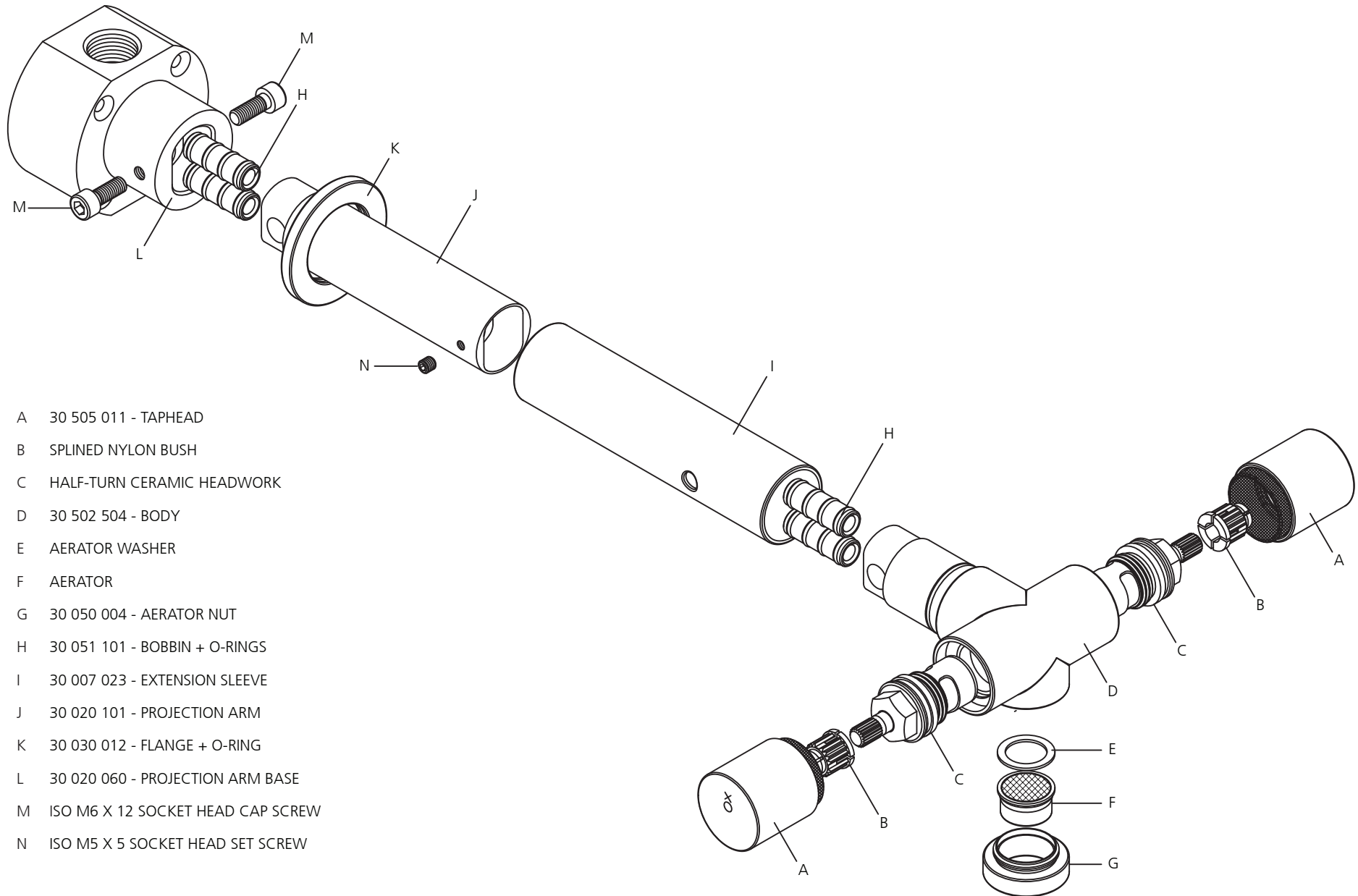

- A 30 505 011 - TAPHEAD
- B SPLINED NYLON BUSH
- C HALF-TURN CERAMIC HEADWORK
- D 30 502 504 - BODY
- E AERATOR WASHER
- F AERATOR
- G 30 050 004 - AERATOR NUT
- H 30 051 101 - BOBBIN + O-RINGS
- I 30 007 023 - EXTENSION SLEEVE
- J 30 020 101 - PROJECTION ARM
- K 30 030 012 - FLANGE + O-RING
- L 30 020 060 - PROJECTION ARM BASE
- M ISO M6 X 12 SOCKET HEAD CAP SCREW
- N ISO M5 X 5 SOCKET HEAD SET SCREW