



LEFROY BROOKS

IBROC HOUSE ESSEX ROAD
HODDESDON HERTS EN11 OQS UK
T: +44 (0)1992 708 316 F: +44 (0)1992 708 317

XO-3102

JO MONO - WALL MOUNTED FOR BATH

DIMENSIONAL DATA SHEET

DATE: 19 August 2010

NUMBER: 30 069 3102 B

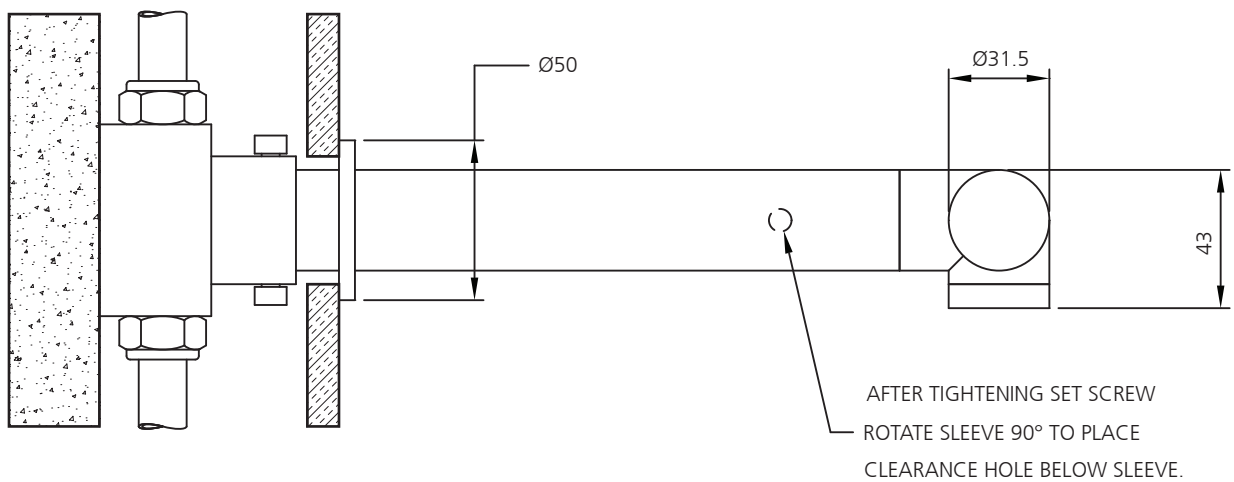
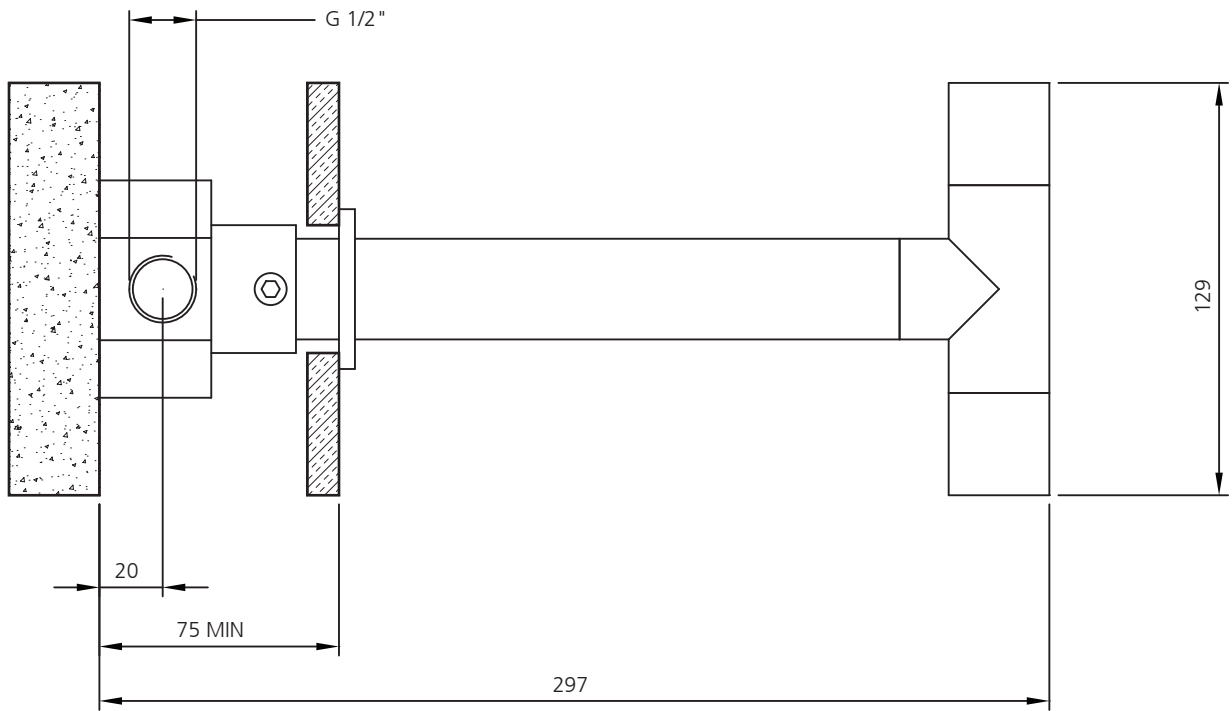

DIMENSIONS IN MILLIMETRES

WHILST EVERY EFFORT IS MADE TO ENSURE THE ACCURACY OF THESE DATA SHEETS THEY ARE SUBJECT TO CHANGE WITHOUT NOTICE AS PART OF THE COMPANY'S PRODUCT DEVELOPMENT PROCESS

XO-3102

JO MONO - WALL MOUNTED FOR BATH

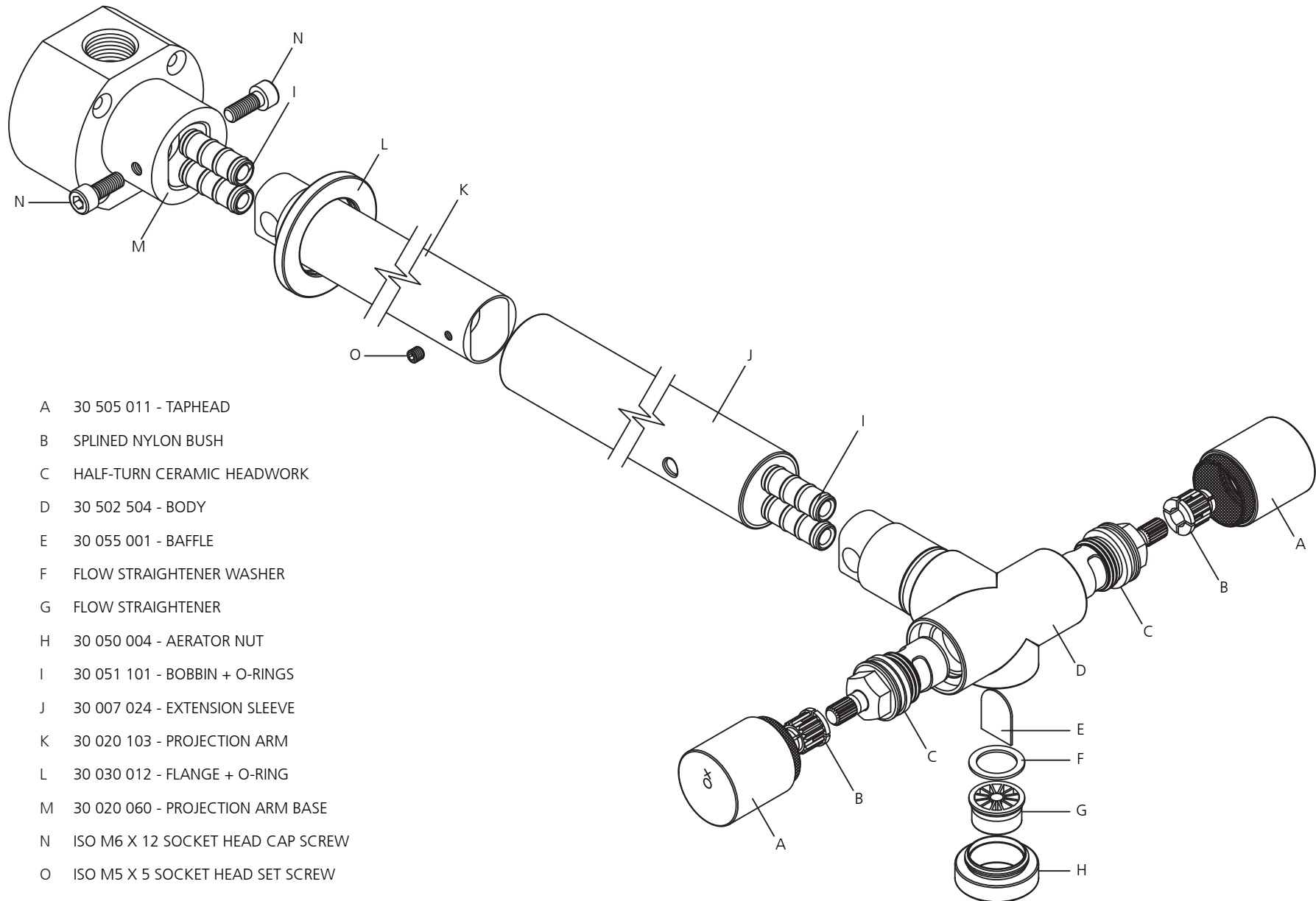

- A 30 505 011 - TAPHEAD
- B SPLINED NYLON BUSH
- C HALF-TURN CERAMIC HEADWORK
- D 30 502 504 - BODY
- E 30 055 001 - BAFFLE
- F FLOW STRAIGHTENER WASHER
- G FLOW STRAIGHTENER
- H 30 050 004 - AERATOR NUT
- I 30 051 101 - BOBBIN + O-RINGS
- J 30 007 024 - EXTENSION SLEEVE
- K 30 020 103 - PROJECTION ARM
- L 30 030 012 - FLANGE + O-RING
- M 30 020 060 - PROJECTION ARM BASE
- N ISO M6 X 12 SOCKET HEAD CAP SCREW
- O ISO M5 X 5 SOCKET HEAD SET SCREW